

Jaringan Komputer (IF8505)

Network layer

Topik bahasan

- Prinsip dasar
- algoritma routing
- algoritma congestion control
- internetworking

Prinsip dasar

- Network layer memiliki peta topologi jaringan: mampu meneruskan paket hingga ke tujuan
- layer ini mengatur terjadinya congestion dengan cara mengatur flow control
- ke layer transport:
 - menyediakan pengalamatan host yang uniform
 - menyediakan layanan connection oriented virtual circuit dan/atau connectionless datagram

3

Store-and-Forward Packet Switching

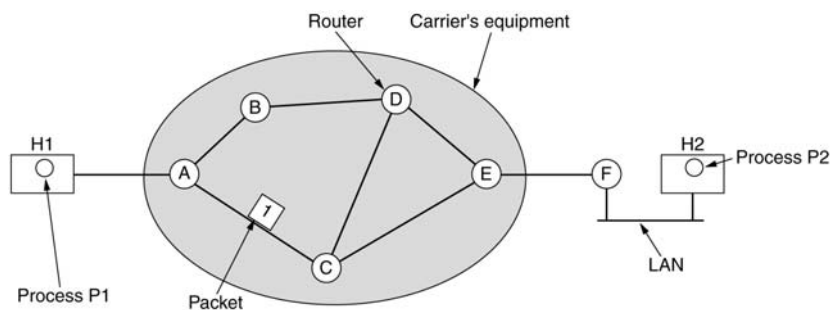

The environment of the network layer protocols.

Connection oriented virtual circuit

- menghindari memilih rute baru untuk setiap paket yang dikirimkan
- saat koneksi dibuat, rute yang akan dilalui oleh paket ditentukan, dan setiap router pada path yang dilewati akan mengingat rute tersebut
- resource yang dibutuhkan (buffer untuk menyimpan paket) dialokasikan
- saat koneksi diakhiri, resource didealokasikan

5

Implementation of Connection-Oriented Service

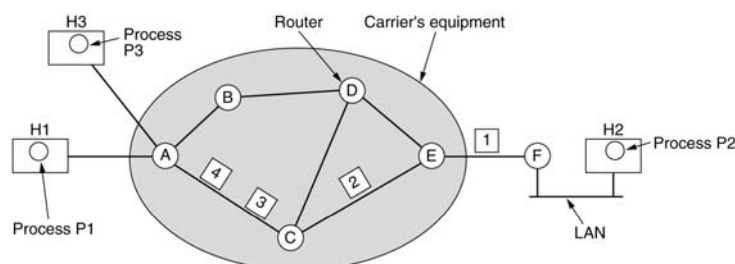

A's table		C's table		E's table	
H1	1	A	1	C	1
H3	1	A	2	C	2
	C	E	1	F	1
	C	E	2	F	2
In	Out				

Routing within a virtual-circuit subnet.

Connectionless datagram

- rute tidak ditentukan dari awal
- setiap paket dapat menempuh jalur yang berbeda-beda
- setiap paket harus berisi informasi tujuan lengkap

7

Implementation of Connectionless Service

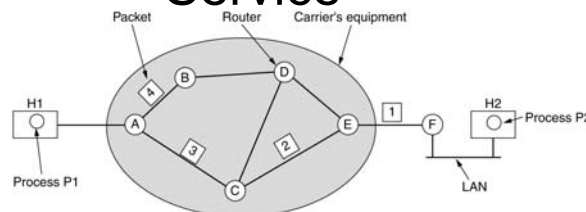

A's table

initially	later
A: -	A: -
B: B	B: B
C: C	C: C
D: B	D: B
E: C	E: B
F: C	F: B

C's table

A: A
B: A
C: -
D: D
E: E
F: E

E's table

A: C
B: D
C: C
D: D
E: -
F: F

Dest. Line

Routing within a diagram subnet.

Comparison of Virtual-Circuit and Datagram Subnets

Issue	Datagram subnet	Virtual-circuit subnet
Circuit setup	Not needed	Required
Addressing	Each packet contains the full source and destination address	Each packet contains a short VC number
State information	Routers do not hold state information about connections	Each VC requires router table space per connection
Routing	Each packet is routed independently	Route chosen when VC is set up; all packets follow it
Effect of router failures	None, except for packets lost during the crash	All VCs that passed through the failed router are terminated
Quality of service	Difficult	Easy if enough resources can be allocated in advance for each VC
Congestion control	Difficult	Easy if enough resources can be allocated in advance for each VC

Algoritma routing

- The Optimality Principle
- Shortest Path Routing
- Flooding
- Distance Vector Routing
- Link State Routing
- Hierarchical Routing
- Broadcast Routing
- Multicast Routing
- Routing for Mobile Hosts
- Routing in Ad Hoc Networks

Algoritma routing

- algoritma routing berfungsi untuk menentukan ke arah mana sebuah paket harus diteruskan
- routing memiliki 2 fase:
 - fase penentuan rute: routers saling bertukar informasi untuk menentukan rute yang paling baik, kemudian rute ini disimpan dalam sebuah tabel
 - forwarding: meneruskan paket ke tujuannya berdasarkan tabel yang dibangun pada fase 1.

11

Algoritma routing

- algoritma routing yang bagus memiliki properties:
 - robustness: mampu berfungsi baik dalam kondisi jaringan yang berubah-ubah
 - stability: selalu dapat kembali ke kondisi stabil
 - fairness & optimality

12

algoritma routing

- algoritma routing dapat dibagi menjadi 2:
 - Adaptive: menyesuaikan tabel routing sesuai dengan kondisi jaringan saat itu
 - Non adaptive/static: tidak menyesuaikan dengan kondisi jaringan. Tabel routing dibuat di awal, dan tidak berubah selama jaringan tersebut berjalan

13

Routing Algorithms (2)

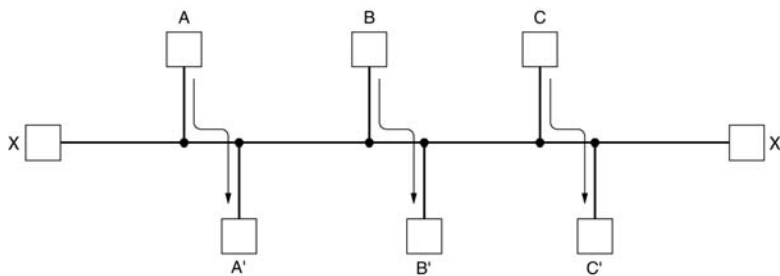

Conflict between fairness and optimality.

Optimality principle

- jika J berada pada jalur optimal dari I ke K, maka rute J ke K akan menggunakan jalur optimal yang sama
- sebuah node dapat menentukan rute terbaik berdasarkan rute terbaik tetangganya

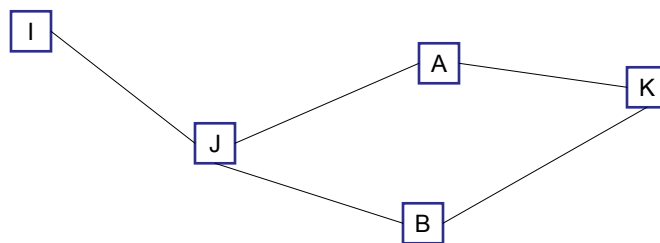

15

The Optimality Principle

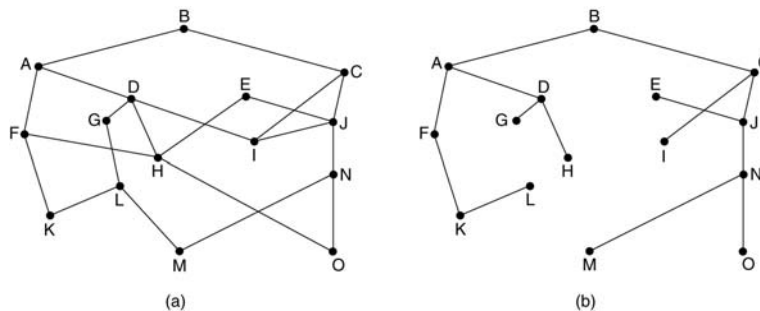

(a) A subnet. (b) A sink tree for router B.

Shortest path routing

- membangun graf dimana node merepresentasikan router dan arc merepresentasikan jarak/cost
- algoritma shortest path digunakan untuk menentukan jarak terpendek antar setiap node pada graf.
- metrik yang digunakan untuk merepresentasikan jarak/cost: jumlah hop, delay, queueing delay

17

Shortest Path Routing

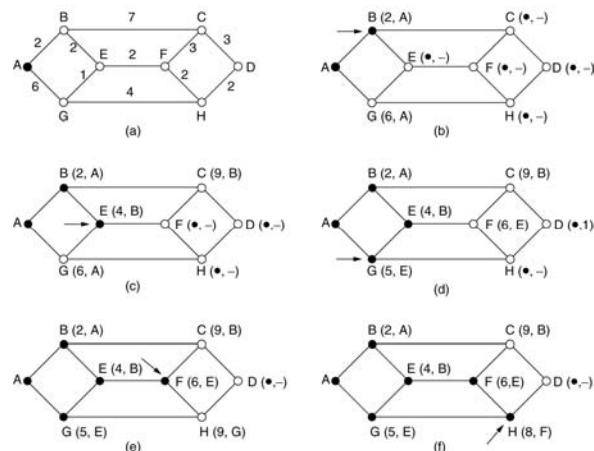

The first 5 steps used in computing the shortest path from A to D.

The arrows indicate the working node.

Flooding

- flooding adalah teknik routing dimana sebuah paket akan diteruskan ke semua jalur kecuali ke jalur asal paket tersebut
- flooding akan menghasilkan banyak paket duplikat: perlu kontrol untuk membatasi flooding berlebihan, misalnya dengan menghitung hop count
- paket pertama akan sampai ke tujuan melalui shortest path

Distance vector routing

- setiap router menyimpan tabel yang berisi tentatif rute terbaik ke semua node, serta costnya
- secara periodik, router bertukar informasi, dan jika ada tetangga nya yang memiliki rute lebih baik, router tersebut akan mengupdate tabelnya
- nama lain: Bellman-Ford algorithm & Ford-Fulkerson algorithm

Distance Vector Routing

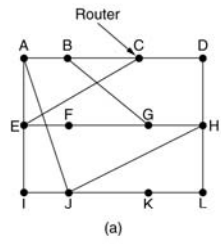

To	A	I	H	K	New estimated delay from J
A	0	24	20	21	8 A
B	12	36	31	28	20 A
C	25	18	19	36	28 I
D	40	27	8	24	20 H
E	14	7	30	22	17 I
F	23	20	19	40	30 I
G	18	31	6	31	18 H
H	17	20	0	19	12 H
I	21	0	14	22	10 I
J	9	11	7	10	0 -
K	24	22	22	0	6 K
L	29	33	9	9	15 K

JA delay is 8
 JI delay is 10
 JH delay is 12
 JK delay is 6

Vectors received from J's four neighbors

New routing table for J

(a) A subnet. (b) Input from A, I, H, K, and the new routing table for J.

Distance Vector Routing (2)

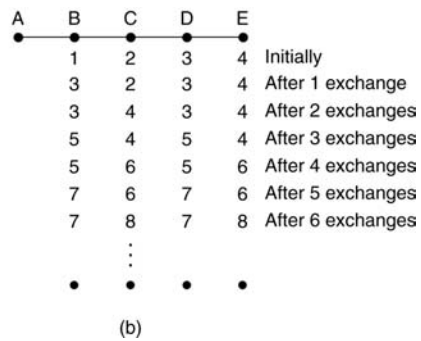
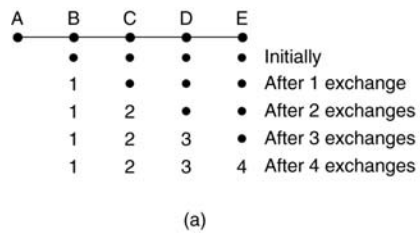

The count-to-infinity problem.

Link State Routing

Each router must do the following:

1. Discover its neighbors, learn their network address.
2. Measure the delay or cost to each of its neighbors.
3. Construct a packet telling all it has just learned.
4. Send this packet to all other routers.
5. Compute the shortest path to every other router.

Learning about the Neighbors

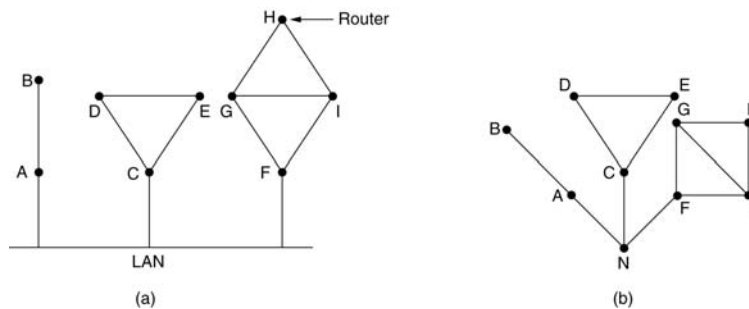

(a) Nine routers and a LAN. (b) A graph model of (a).

Measuring Line Cost

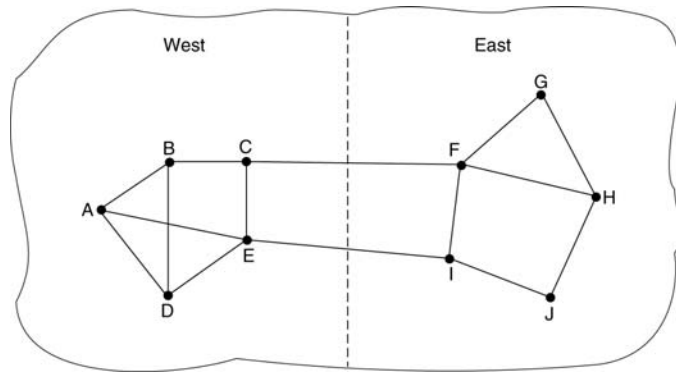

A subnet in which the East and West parts are connected by two lines.

Building Link State Packets

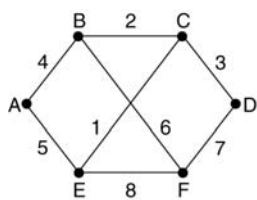

(a)

Link		State		Packets							
A	B	C	D	E	F						
Seq.	Seq.	Seq.	Seq.	Seq.	Seq.						
Age	Age	Age	Age	Age	Age						
B	4	A	4	B	2	C	3	A	5	B	6
E	5	C	2	D	3	F	7	C	1	D	7
		F	6	E	1			F	8	E	8

(b)

(a) A subnet. (b) The link state packets for this subnet.

Distributing the Link State Packets

Source	Seq.	Age	Send flags			ACK flags			Data
			A	C	F	A	C	F	
A	21	60	0	1	1	1	0	0	
F	21	60	1	1	0	0	0	1	
E	21	59	0	1	0	1	0	1	
C	20	60	1	0	1	0	1	0	
D	21	59	1	0	0	0	1	1	

The packet buffer for router B in the previous slide (Fig. 5-13).

Hierarchical Routing

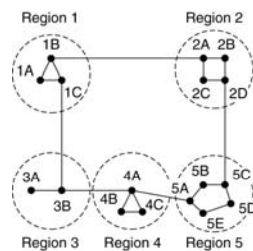

(a)

Full table for 1A

Dest.	Line	Hops
1A	—	—
1B	1B	1
1C	1C	1
2A	1B	2
2B	1B	3
2C	1B	3
2D	1B	4
3A	1C	3
3B	1C	2
4A	1C	3
4B	1C	4
4C	1C	4
5A	1C	4
5B	1C	5
5C	1B	5
5D	1C	6
5E	1C	5

(b)

Hierarchical table for 1A

Dest.	Line	Hops
1A	—	—
1B	1B	1
1C	1C	1
2	1B	2
3	1C	2
4	1C	3
5	1C	4

(c)

Hierarchical routing.

Broadcast Routing

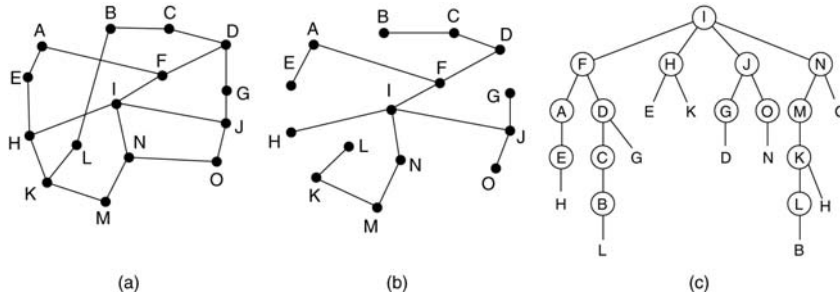

Reverse path forwarding. (a) A subnet. (b) a Sink tree. (c) The tree built by reverse path forwarding.

Multicast Routing

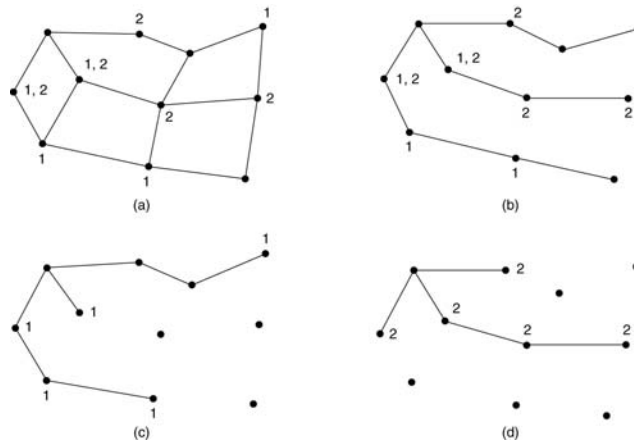

(a) A network. (b) A spanning tree for the leftmost router. (c) A multicast tree for group 1. (d) A multicast tree for group 2.

Routing for Mobile Hosts

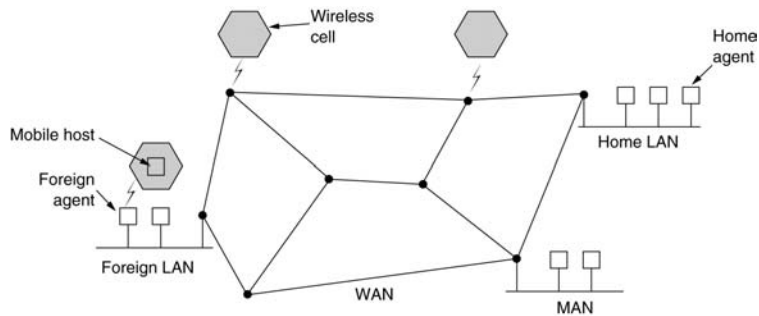

A WAN to which LANs, MANs, and wireless cells are attached.

Routing for Mobile Hosts (2)

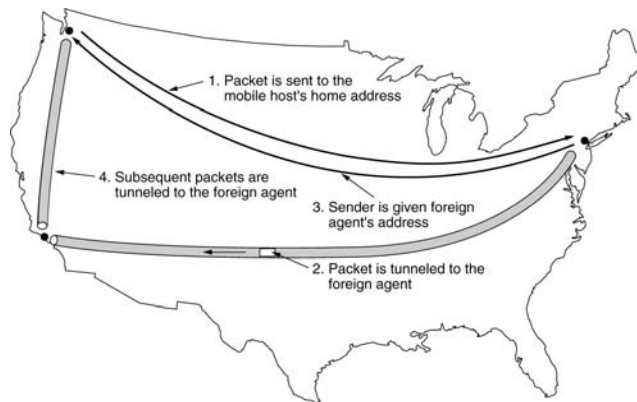

Packet routing for mobile users.

Routing in Ad Hoc Networks

Possibilities when the routers are mobile:

1. Military vehicles on battlefield.

– No infrastructure.

2. A fleet of ships at sea.

– All moving all the time

3. Emergency works at earthquake .

– The infrastructure destroyed.

4. A gathering of people with notebook computers.

– In an area lacking 802.11.

Route Discovery

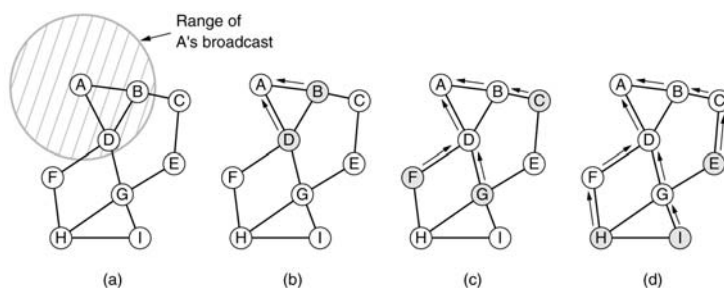

- (a) Range of A's broadcast.
- (b) After B and D have received A's broadcast.
- (c) After C, F, and G have received A's broadcast.
- (d) After E, H, and I have received A's broadcast.

Shaded nodes are new recipients. Arrows show possible reverse routes.

Route Discovery (2)

Source address	Request ID	Destination address	Source sequence #	Dest. sequence #	Hop count
----------------	------------	---------------------	-------------------	------------------	-----------

Format of a ROUTE REQUEST packet.

Route Discovery (3)

Source address	Destination address	Destination sequence #	Hop count	Lifetime
----------------	---------------------	------------------------	-----------	----------

Format of a ROUTE REPLY packet.

Route Maintenance

Dest.	Next hop	Distance	Active neighbors	Other fields
A	A	1	F, G	
B	B	1	F, G	
C	B	2	F	
E	G	2		
F	F	1	A, B	
G	G	1	A, B	
H	F	2	A, B	
I	G	2	A, B	

(a)

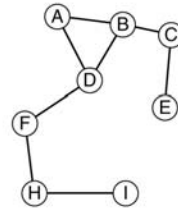

(b)

- (a) D's routing table before G goes down.
- (b) The graph after G has gone down.

Node Lookup in Peer-to-Peer Networks

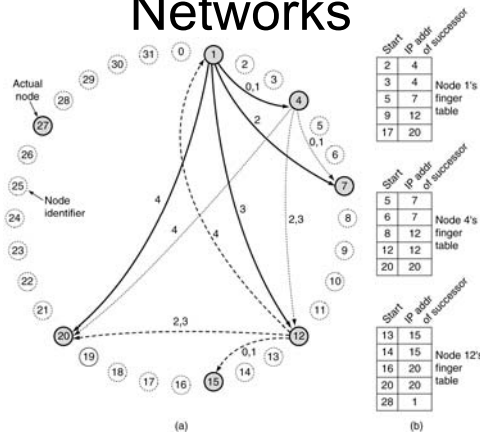

(a)

(b)

- (a) A set of 32 node identifiers arranged in a circle. The shaded ones correspond to actual machines. The arcs show the fingers from nodes 1, 4, and 12. The labels on the arcs are the table indices.
- (b) Examples of the finger tables.

Congestion Control Algorithms

- General Principles of Congestion Control
- Congestion Prevention Policies
- Congestion Control in Virtual-Circuit Subnets
- Congestion Control in Datagram Subnets
- Load Shedding
- Jitter Control

Congestion

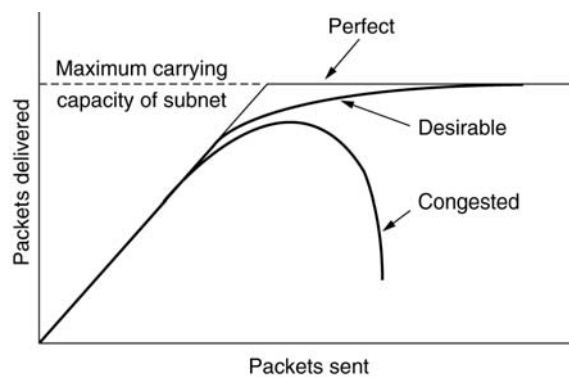

When too much traffic is offered, congestion sets in and performance degrades sharply.

General Principles of Congestion Control

1. Monitor the system .
 - detect when and where congestion occurs.
2. Pass information to where action can be taken.
3. Adjust system operation to correct the problem.

Congestion Prevention Policies

Layer	Policies
Transport	<ul style="list-style-type: none">• Retransmission policy• Out-of-order caching policy• Acknowledgement policy• Flow control policy• Timeout determination
Network	<ul style="list-style-type: none">• Virtual circuits versus datagram inside the subnet• Packet queueing and service policy• Packet discard policy• Routing algorithm• Packet lifetime management
Data link	<ul style="list-style-type: none">• Retransmission policy• Out-of-order caching policy• Acknowledgement policy• Flow control policy

Policies that affect congestion.

Congestion Control in Virtual-Circuit Subnets

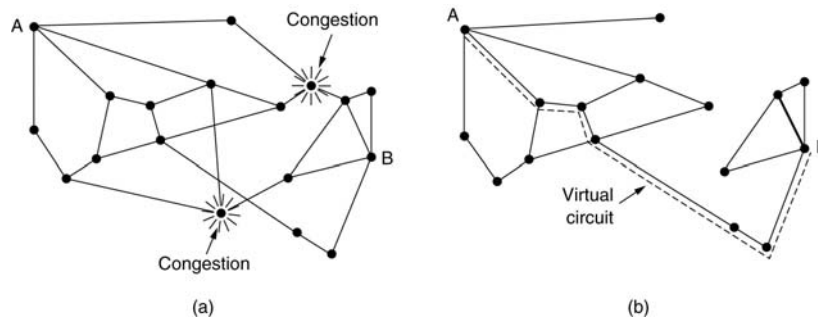

(a) A congested subnet. (b) A redrawn subnet, eliminates congestion and a virtual circuit from A to B.

Congestion control in datagram subnet

- line utilization: $u = au_{old} + (1-a)f$
- warning bit
- choke packet
- hop by hop choke packet

Hop-by-Hop Choke Packets

- (a) A choke packet that affects only the source.
- (b) A choke packet that affects each hop it passes through.

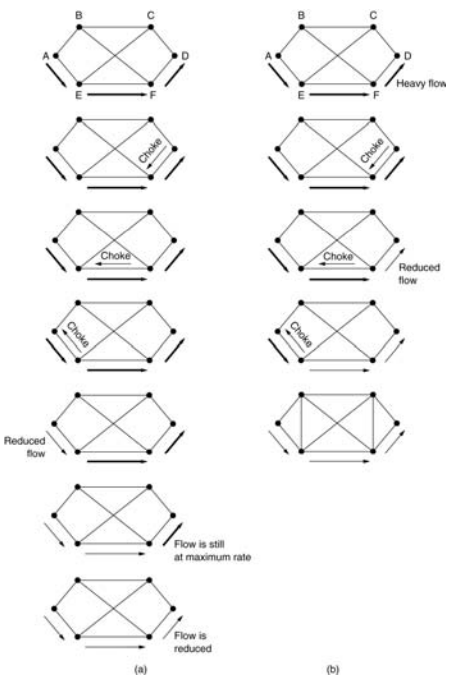

Jitter Control

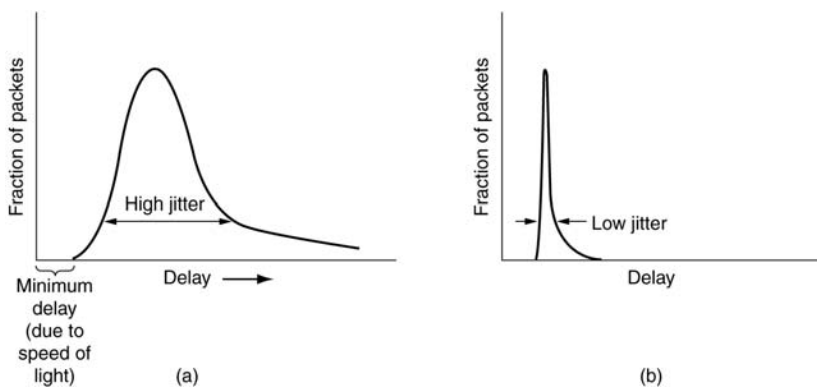

(a) High jitter.

(b) Low jitter.

Quality of Service

- Requirements
- Techniques for Achieving Good Quality of Service
- Integrated Services
- Differentiated Services
- Label Switching and MPLS

Requirements

Application	Reliability	Delay	Jitter	Bandwidth
E-mail	High	Low	Low	Low
File transfer	High	Low	Low	Medium
Web access	High	Medium	Low	Medium
Remote login	High	Medium	Medium	Low
Audio on demand	Low	Low	High	Medium
Video on demand	Low	Low	High	High
Telephony	Low	High	High	Low
Videoconferencing	Low	High	High	High

How stringent the quality-of-service requirements are.

Teknik menyediakan QoS

- over provisioning
- buffering
- traffic shaping: leaky bucket, token bucket
- resource reservation
- admission control
- packet scheduling

49

Buffering

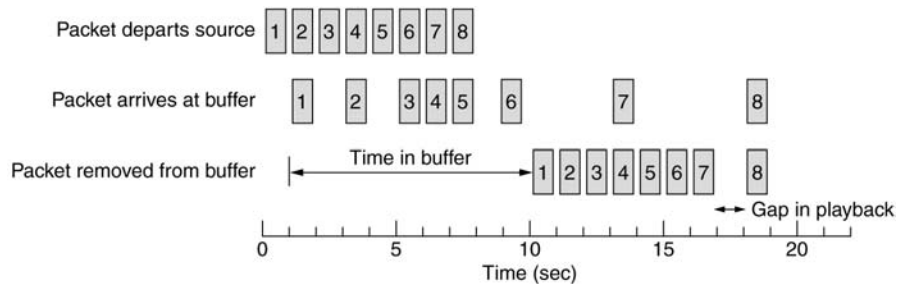

Smoothing the output stream by buffering packets.

The Leaky Bucket Algorithm

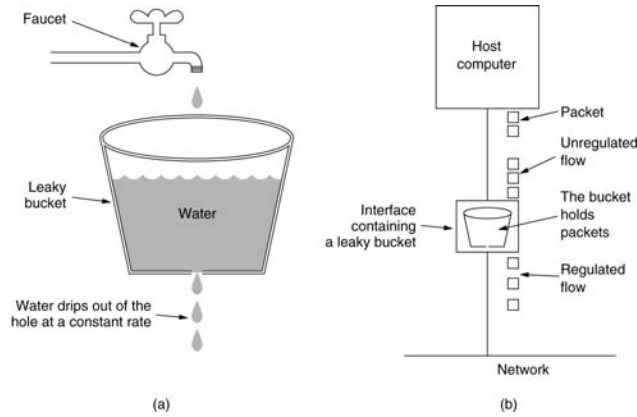

(a) A leaky bucket with water. (b) a leaky bucket with packets.

The Leaky Bucket Algorithm

(a) Input to a leaky bucket.
 (b) Output from a leaky bucket. Output from a token bucket with capacities of (c) 250 KB, (d) 500 KB, (e) 750 KB, (f) Output from a 500KB token bucket feeding a 10-MB/sec leaky bucket.

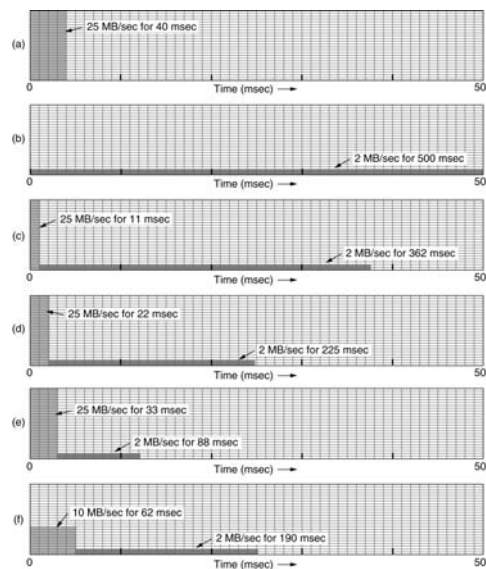

The Token Bucket Algorithm

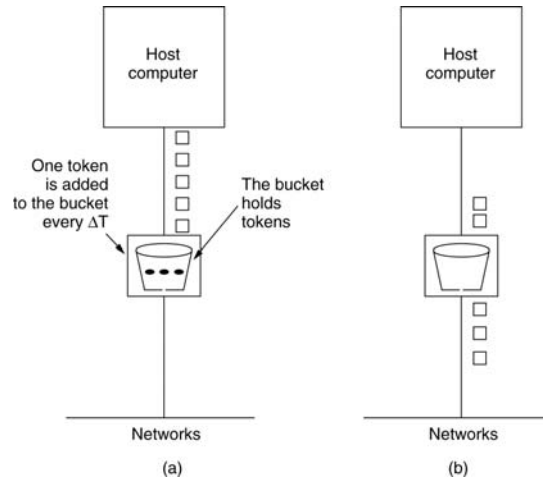

(a) Before. (b) After.

Token bucket algorithm

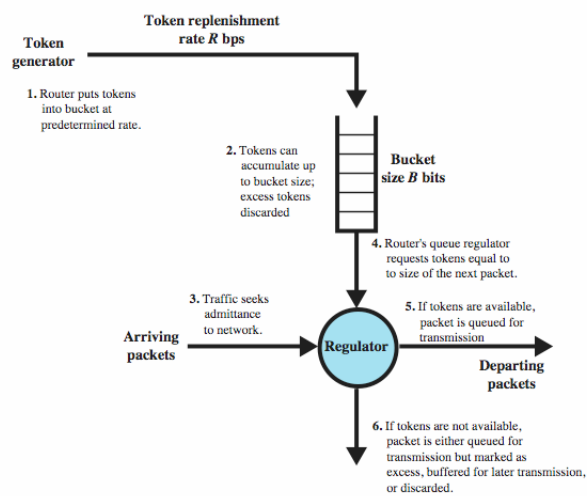

Admission Control

Parameter	Unit
Token bucket rate	Bytes/sec
Token bucket size	Bytes
Peak data rate	Bytes/sec
Minimum packet size	Bytes
Maximum packet size	Bytes

An example of flow specification.

Packet Scheduling

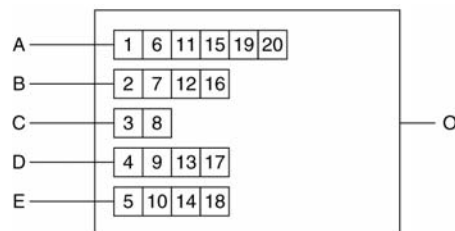

(a)

Packet	Finishing time
C	8
B	16
D	17
E	18
A	20

(b)

- (a) A router with five packets queued for line O.
(b) Finishing times for the five packets.

Integrated services

- an architecture to provide flow based QoS
- every router in the system implements IntServ
- application must request resource reservation
- resource reservation provides information such as bandwidth, delay, traffic shape

57

RSVP-The ReSerVation Protocol

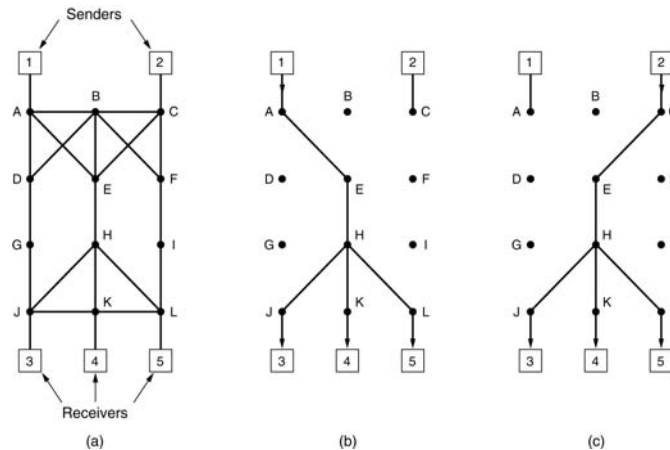

- (a) A network, (b) The multicast spanning tree for host 1.
(c) The multicast spanning tree for host 2.

RSVP-The ReSerVation Protocol

(2)

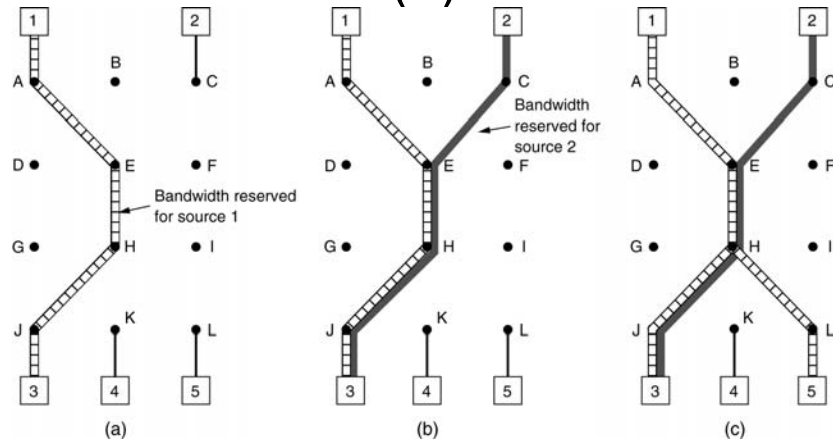

(a) Host 3 requests a channel to host 1. (b) Host 3 then requests a second channel, to host 2. (c) Host 5 requests a channel to host 1.

Differentiated services

- an architecture to provide class based QoS
- layanan DS disediakan oleh provider yang mengelola sekumpulan router yang disetup untuk menyediakan DS (DS domain)
- user mengadakan perjanjian (SLA) dengan provider untuk jenis layanan yang disediakan
- packet dikirimkan menggunakan label (ToS field pada IPv4 header)

Expedited Forwarding

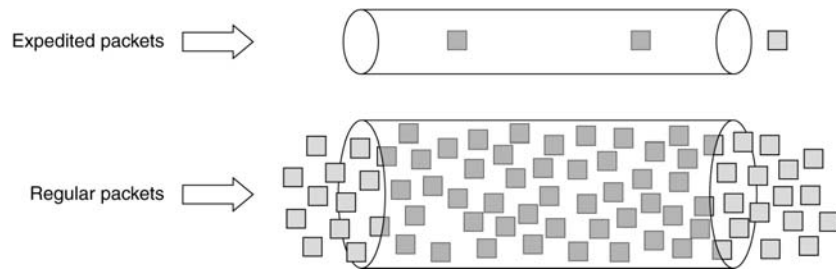

Expedited packets experience a traffic-free network.

Assured Forwarding

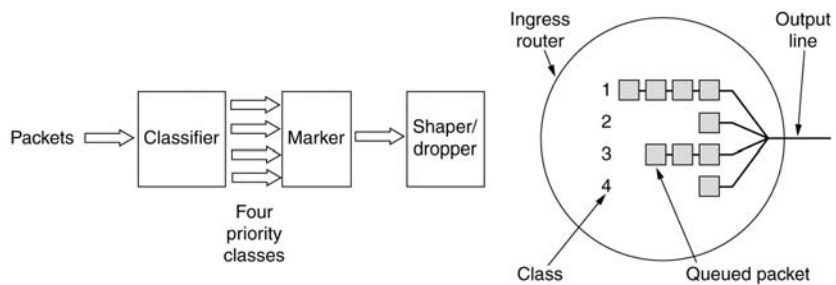

A possible implementation of the data flow for assured forwarding.

Label Switching and MPLS

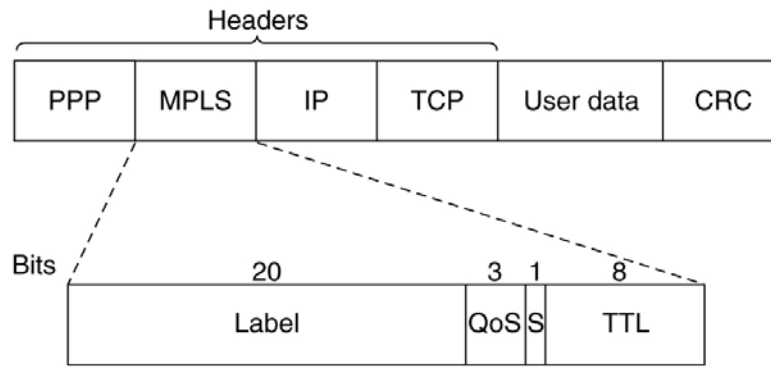

Transmitting a TCP segment using IP, MPLS, and PPP.

Internetworking

- How Networks Differ
- How Networks Can Be Connected
- Concatenated Virtual Circuits
- Connectionless Internetworking
- Tunneling
- Internetwork Routing
- Fragmentation

Connecting Networks

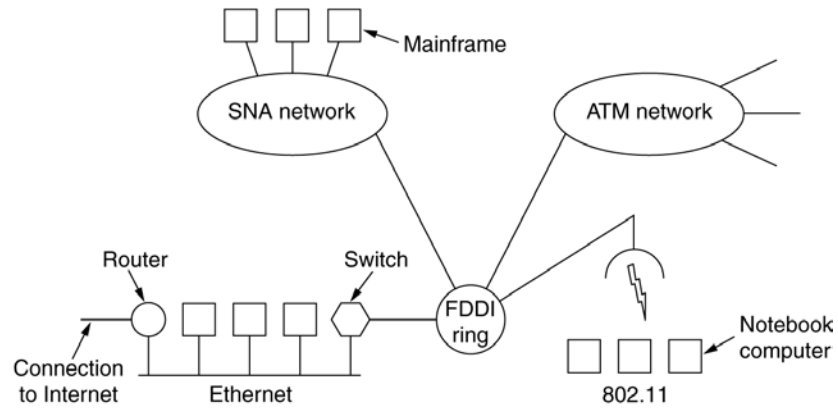

A collection of interconnected networks.

How Networks Differ

Item	Some Possibilities
Service offered	Connection oriented versus connectionless
Protocols	IP, IPX, SNA, ATM, MPLS, AppleTalk, etc.
Addressing	Flat (802) versus hierarchical (IP)
Multicasting	Present or absent (also broadcasting)
Packet size	Every network has its own maximum
Quality of service	Present or absent; many different kinds
Error handling	Reliable, ordered, and unordered delivery
Flow control	Sliding window, rate control, other, or none
Congestion control	Leaky bucket, token bucket, RED, choke packets, etc.
Security	Privacy rules, encryption, etc.
Parameters	Different timeouts, flow specifications, etc.
Accounting	By connect time, by packet, by byte, or not at all

Some of the many ways networks can differ.

How Networks Can Be Connected

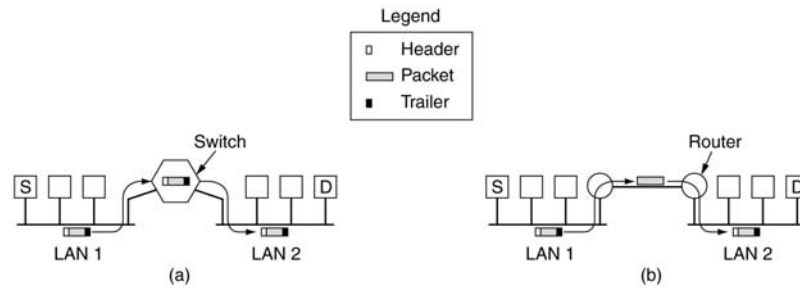

- (a) Two Ethernets connected by a switch.
- (b) Two Ethernets connected by routers.

Concatenated Virtual Circuits

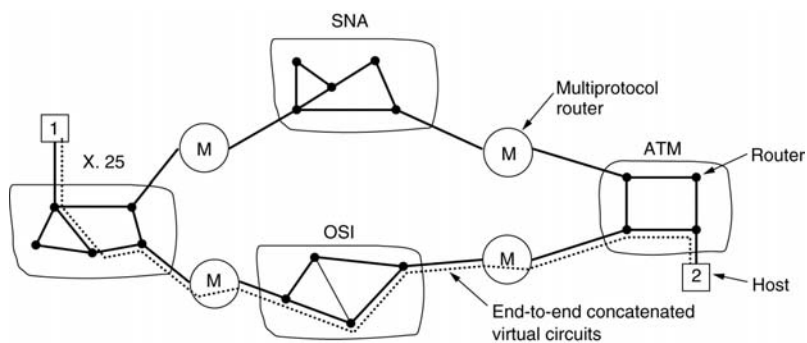

Internetworking using concatenated virtual circuits.

Connectionless Internetworking

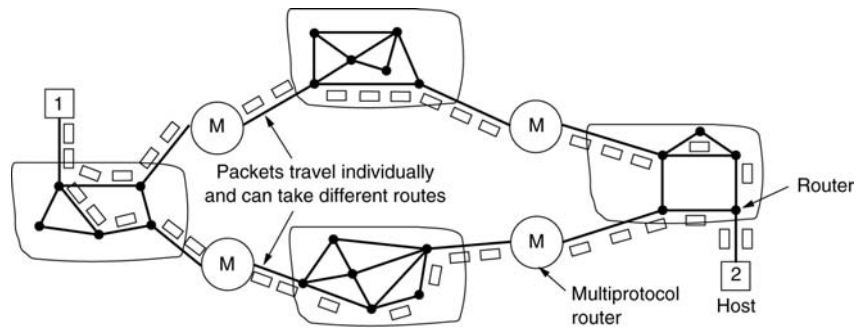

A connectionless internet.

Tunneling

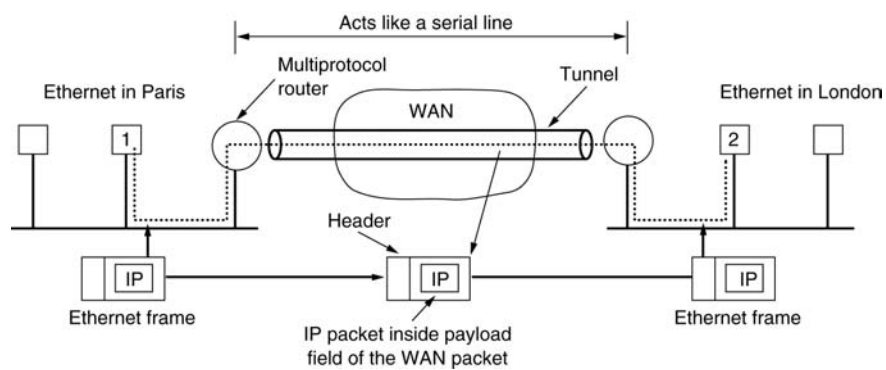

Tunneling a packet from Paris to London.

Tunneling (2)

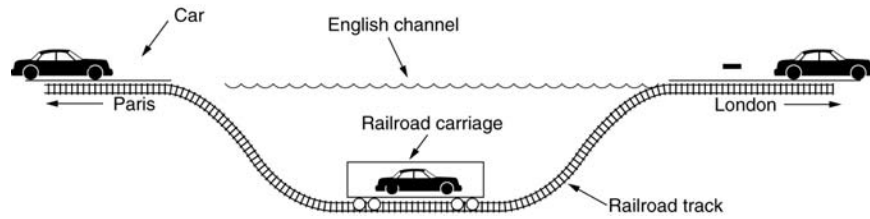

Tunneling a car from France to England.

Internetwork Routing

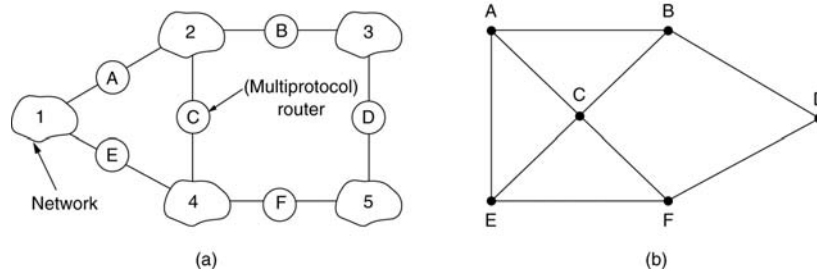

(a) An internetwork. (b) A graph of the internetwork.

Fragmentation

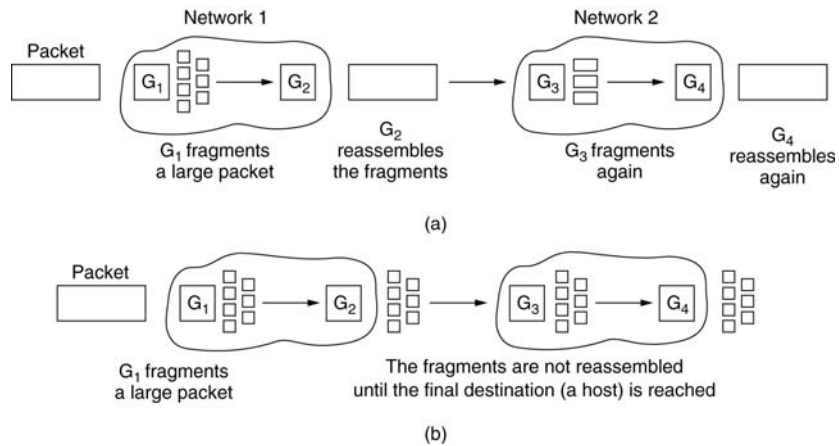

(a) Transparent fragmentation. (b) Nontransparent fragmentation.

Fragmentation (2)

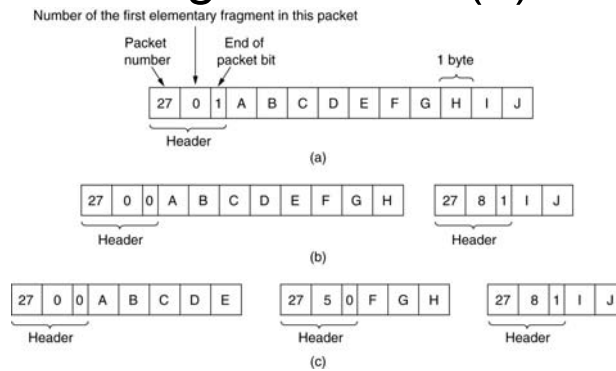

Fragmentation when the elementary data size is 1 byte.

- (a) Original packet, containing 10 data bytes.
- (b) Fragments after passing through a network with maximum packet size of 8 payload bytes plus header.
- (c) Fragments after passing through a size 5 gateway.

The Network Layer in the Internet

- The IP Protocol
- IP Addresses
- Internet Control Protocols
- OSPF – The Interior Gateway Routing Protocol
- BGP – The Exterior Gateway Routing Protocol
- Internet Multicasting
- Mobile IP
- IPv6

Design Principles for Internet

1. Make sure it works.
2. Keep it simple.
3. Make clear choices.
4. Exploit modularity.
5. Expect heterogeneity.
6. Avoid static options and parameters.
7. Look for a good design; it need not be perfect.
8. Be strict when sending and tolerant when receiving.
9. Think about scalability.
10. Consider performance and cost.

Collection of Subnetworks

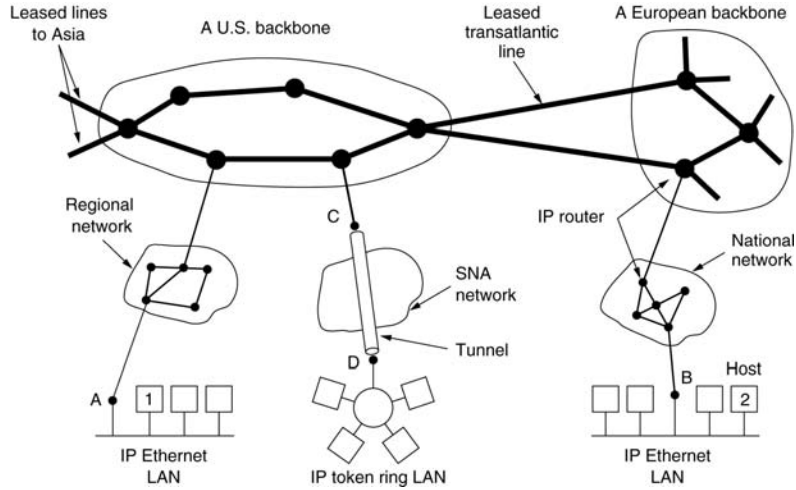

The Internet is an interconnected collection of many networks.

The IP Protocol

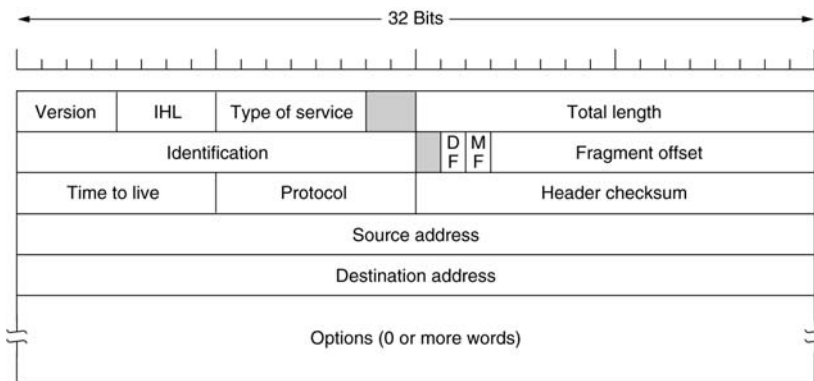

The IPv4 (Internet Protocol) header.

The IP Protocol (2)

Option	Description
Security	Specifies how secret the datagram is
Strict source routing	Gives the complete path to be followed
Loose source routing	Gives a list of routers not to be missed
Record route	Makes each router append its IP address
Timestamp	Makes each router append its address and timestamp

Some of the IP options.

IP Addresses

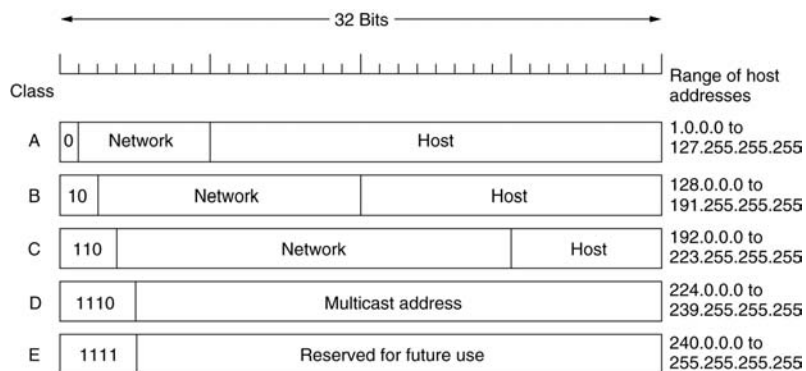

IP address formats.

IP Addresses (2)

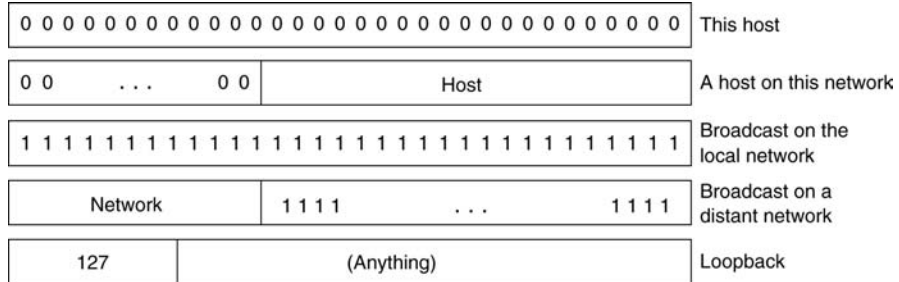

Special IP addresses.

Subnets

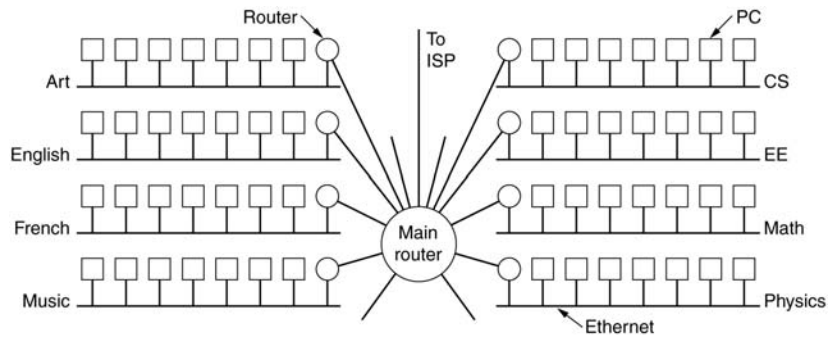

A campus network consisting of LANs for various departments.

Subnets (2)

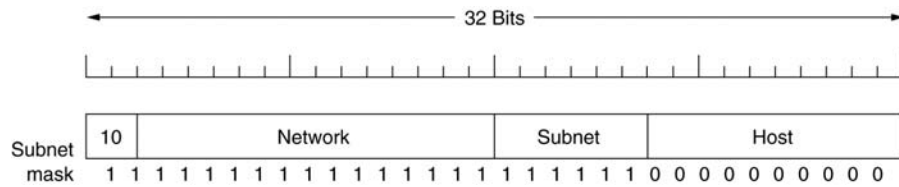

A class B network subnetted into 64 subnets.

CDR – Classless InterDomain Routing

University	First address	Last address	How many	Written as
Cambridge	194.24.0.0	194.24.7.255	2048	194.24.0.0/21
Edinburgh	194.24.8.0	194.24.11.255	1024	194.24.8.0/22
(Available)	194.24.12.0	194.24.15.255	1024	194.24.12/22
Oxford	194.24.16.0	194.24.31.255	4096	194.24.16.0/20

A set of IP address assignments.

NAT – Network Address Translation

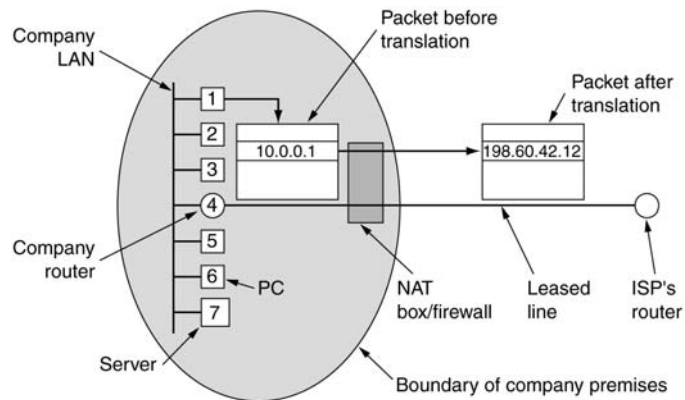

Placement and operation of a NAT box.

Internet Control Message Protocol

Message type	Description
Destination unreachable	Packet could not be delivered
Time exceeded	Time to live field hit 0
Parameter problem	Invalid header field
Source quench	Choke packet
Redirect	Teach a router about geography
Echo request	Ask a machine if it is alive
Echo reply	Yes, I am alive
Timestamp request	Same as Echo request, but with timestamp
Timestamp reply	Same as Echo reply, but with timestamp

The principal ICMP message types.

ARP– The Address Resolution Protocol

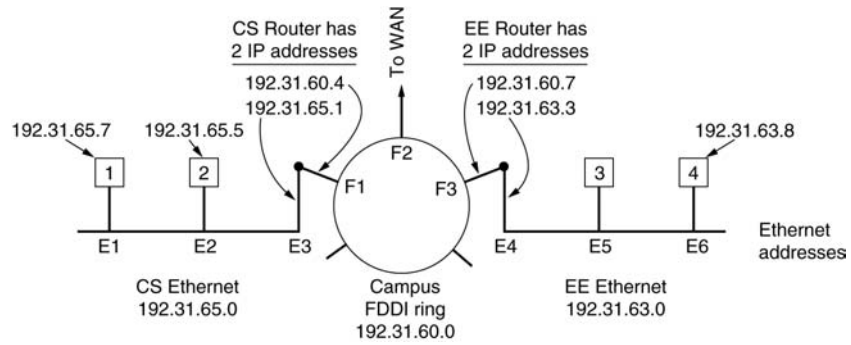

Three interconnected /24 networks: two Ethernets and an FDDI ring.

Dynamic Host Configuration Protocol

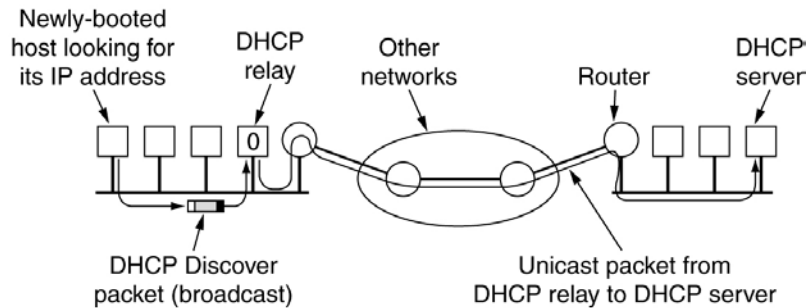

Operation of DHCP.

OSPF – The Interior Gateway Routing Protocol

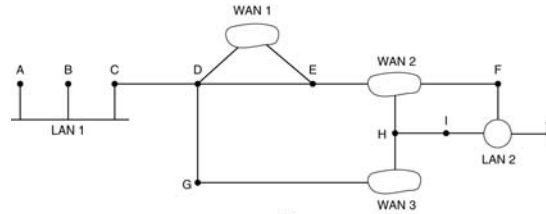

(a)

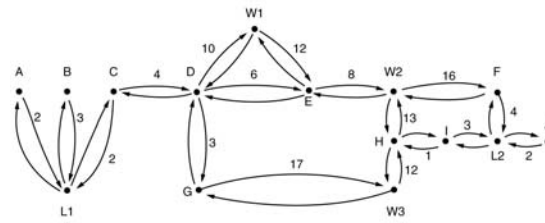

(b)

(a) An autonomous system. (b) A graph representation of (a).

OSPF (2)

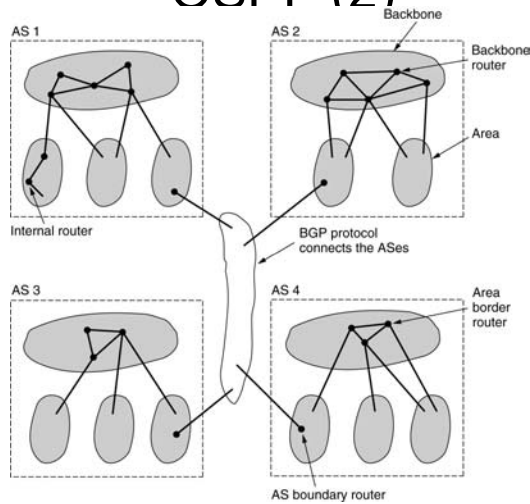

The relation between ASes, backbones, and areas in OSPF.

OSPF (3)

Message type	Description
Hello	Used to discover who the neighbors are
Link state update	Provides the sender's costs to its neighbors
Link state ack	Acknowledges link state update
Database description	Announces which updates the sender has
Link state request	Requests information from the partner

The five types of OSPF messages.

BGP – The Exterior Gateway Routing Protocol

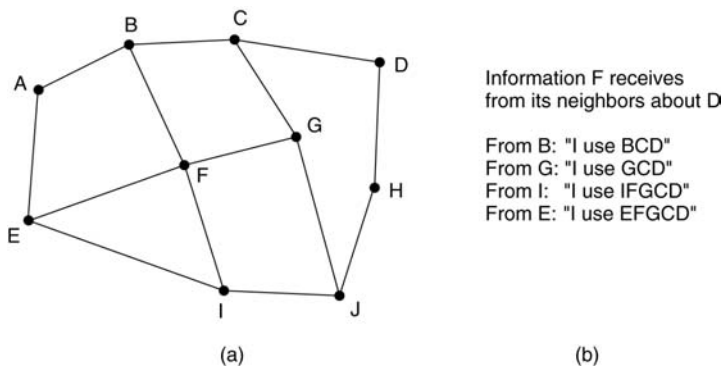

Information F receives from its neighbors about D

From B: "I use BCD"
From G: "I use GCD"
From I: "I use IFGCD"
From E: "I use EFGCD"

(b)

(a) A set of BGP routers. (b) Information sent to F.

The Main IPv6 Header

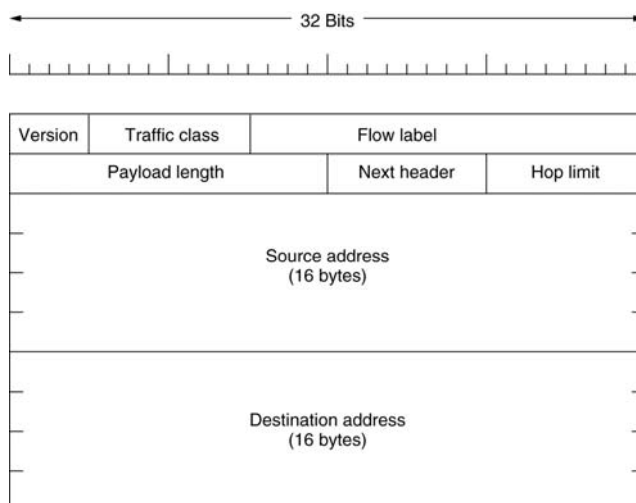

The IPv6 fixed header (required).

Extension Headers

Extension header	Description
Hop-by-hop options	Miscellaneous information for routers
Destination options	Additional information for the destination
Routing	Loose list of routers to visit
Fragmentation	Management of datagram fragments
Authentication	Verification of the sender's identity
Encrypted security payload	Information about the encrypted contents

IPv6 extension headers.

Extension Headers (2)

Next header	0	194	4
Jumbo payload length			

The hop-by-hop extension header for large datagrams (jumbograms).

Extension Headers (3)

Next header	Header extension length	Routing type	Segments left
Type-specific data			

The extension header for routing.